

**DURAMAX**<sup>®</sup>

# DryMax<sup>®</sup> Stern Tube Seal System

- ▶ Water-Lubricated Shaft Seal
- ▶ Engineered for Optimum Sealing Performance

For Propeller Shafts from:  
3.5" - 36" diameter (89-900mm)



## Technical Manual

Duramax Marine is an ISO 9001:2015 Certified Company

**DURAMAX MARINE**<sup>®</sup>



Description of Seal Assembly .....2-3  
 Preparing For DryMax® Seal Installation ..... 4  
 Installation .....4-5  
 Piping ..... 6  
 Inspection Of Installation .....7  
 Operation of DryMax® Seal System .....7  
 Sealing Ring Replacement.....8  
 Parts Replacement Timetables.....9  
 Periodical Inspections .....9  
 Trouble Shooting .....10-11

The DryMax® Stern Tube Seal System was designed, built, and tested by Duramax Marine® in the USA. The seal is a water-lubricated axial shaft seal system constructed of the highest quality materials which are engineered to give you long service life. The DryMax® Shaft Seal is a reliable system that uses no grease or oil and is easy to install and maintain. It is a great addition to a full line of proven and reliable marine products developed by Duramax Marine® and engineered to protect the environment.

- For water lubricated stern tubes
- Has reversible Mating Ring extending dry dock intervals
- Axial seal does NOT wear the propeller shaft
- Easily installed and retrofitted
- Proprietary rubber polymer technology
- DuraChrome® Mating Ring alloy

**General Operation**

The DryMax® Shaft Seal eliminates the wear on propulsion shafts caused by traditional radial lip sealing systems. The unique nature of the DryMax® design creates a highly effective seal which accommodates shaft movement in both the axial and radial directions.

The Duramax® DryMax® Seal is a non-polluting system that has a highly durable and replaceable rubber Sealing Ring. The ring is constructed of proprietary rubber polymer that rotates with the propeller shaft and creates a hydrodynamic sealing interface with the highly polished DuraChrome® Mating Ring.

The DryMax® Seal Ring is engineered to deliver a long operating life and can be easily replaced. The DuraChrome® Mating Ring can be reversed and reused with the spare rubber ring that is stored forward of the seal assembly on the shaft. Once both sides of the DuraChrome® Mating Ring have been worn it can be renewed by machining in a lathe (See pg.11; Appendix E).

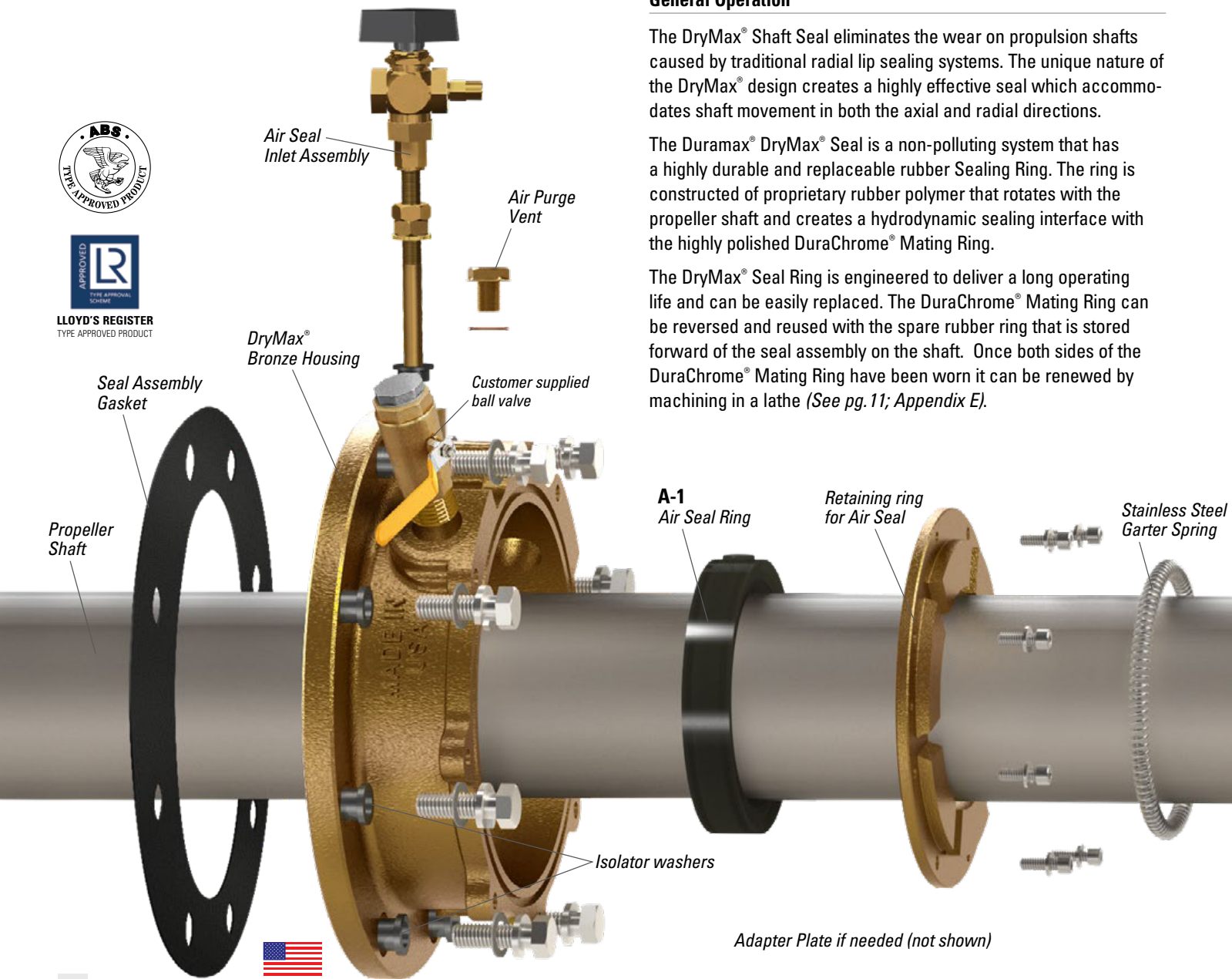

# Main components of DryMax® Seal Assembly

## A-1 DryMax® Inflatable Air Seal Ring

All DryMax® Seals come equipped with an inflatable Air Seal Ring. Air Seal is inflated to a maximum of 80 psi (0.55 MPa) compressed air, it contacts the shaft creating a seal and prevents seawater from entering the ship through the stern tube. This permits inspection and replacement of the primary Seal Ring when the Mating Ring is removed.

**NOTE: DO NOT inflate Air Seal while shaft is rotating.**

If the Air Seal Ring needs to be installed or replaced, follow these instructions:

- Insert Inflatable Air Seal Ring into Seal Housing.
- Screw the main air stem into the Inflatable Ring and hand tight (50 in-lb MAXIMUM).
- Place bronze Inflatable Retainer Ring in the housing and fasten with lock washers and socket head fasteners.
- Slide isolator bushing over the top of the main air stem
- Secure the air stem to the housing with the nut.  
Be careful not to over tighten. DO NOT ROTATE AIR STEM.
- Tighten second lock nut on the air stem.

## A-2 DryMax® Seal Ring

The DryMax® Seal Ring is molded from a proprietary Nitrile rubber formulation that is held to the shaft by a stainless steel garter spring. The Seal Ring rotates with the shaft and makes a seal with the face of the Mating Ring. The design of the Seal Ring accommodates axial shaft movements. The length of the garter spring is predetermined by the factory for proper tension settings.

## A-3 DryMax® DuraChrome® Split Mating Ring

The DryMax® Seal Ring rotates with the shaft and creates a sealing surface against the Mating Ring. The DuraChrome® Mating Ring alloy has been designed to provide optimum sealing and long life when used with our proprietary rubber Sealing Ring. The Mating Ring is a split configuration and is reversible. The Mating Ring can be renewed multiple times by machining the face before replacement is necessary.

### DuraChrome® Mating Ring Specifications:

- Mating Ring surface finish tolerance: 16-32 RMS.
- Mating Ring starting thickness: 1" (25.4mm)
- Wear surface thickness on each side of ring: is approximately 5/16" (8mm)

**Note: Each side of the Mating Ring can be machined down to the indicator mark. DO NOT MACHINE PAST INDICATOR MARK.**

See page 11; Appendix E, for machining specifications and tolerances.

## A-4 Shaft Earthing Device with carbon brush

A Shaft Earthing Device has been supplied with the seal assembly. The device contains a spring loaded carbon brush which makes constant contact with the shaft. This contact grounds the shaft and reduces the chance for damage to the seal caused by stray electrical current. The device should be grounded to the ships hull.

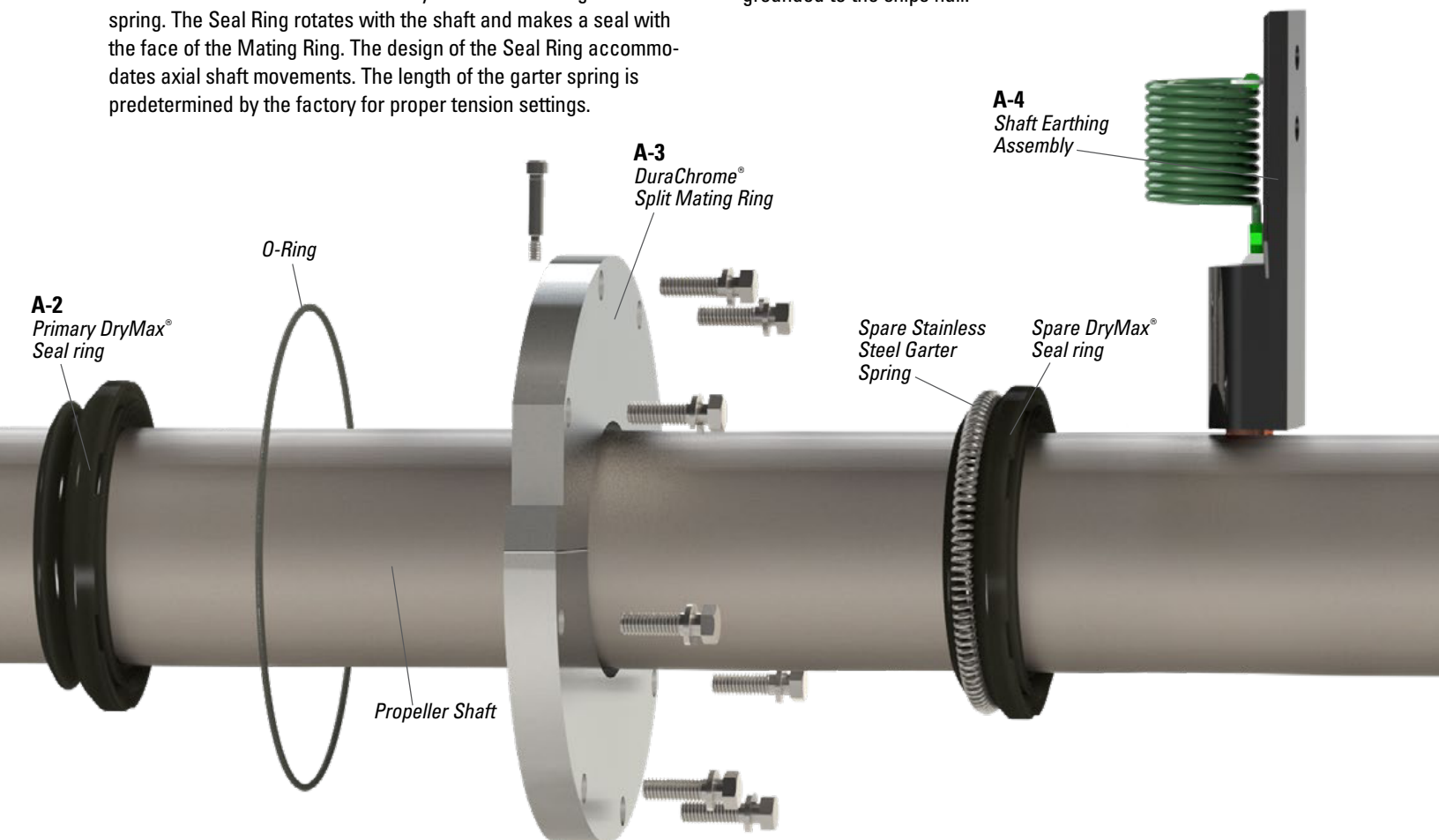

# Installation of DryMax® System. - New Construction

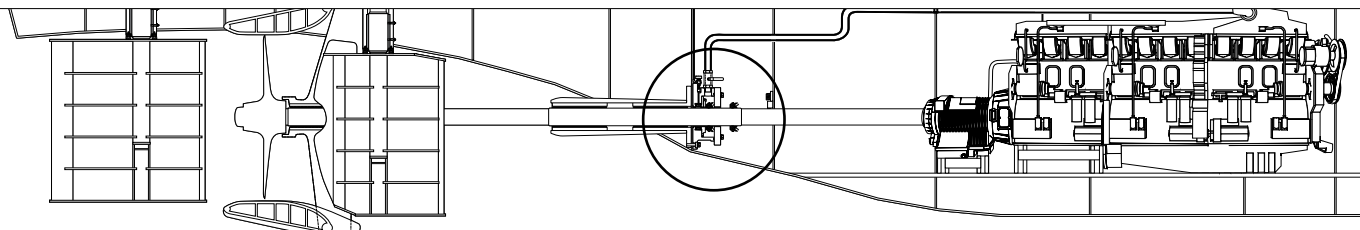

## Prepare Installation

### 1 INSPECTION OF SHAFT, STERN TUBE FLANGE AND BULKHEAD

In new construction it is assumed that the seal will be installed on a new stainless steel shaft or new shaft sleeve or liner. The area should be clean and free from any wear or defects. The surface finish of the shaft or liner in the area in which the rubber Seal Ring will operate must be less than 64 micro inches Ra.

### 2. PERPENDICULARITY OF SHAFT TO MOUNTING AREA

The bulkhead face or stern tube flange where the seal housing will be mounted, should be checked for perpendicularity to the shaft. It is recommended that a dial indicator be used and measurements taken in at least 8 locations around the mounting flange diameter.

The shaft needs to be concentric and square to the seal housing with in 0.020" (.5mm)

**Factory Authorized Service is available.**

**Contact Duramax Marine for details.**

**+1-440-834-5400.**

## Installation of DryMax® System - New Construction

**IMPORTANT: Make sure Air Seal Ring is installed in the DryMax® Bronze Housing before positioning DryMax® System Assembly on shaft.**

1. Step-By-Step Installation Check List (See appendix D). This check list should be filled out and be sent to Duramax Marine for history of installation and confirmation of warranty. A copy of the installation history should be kept in your company records also.
2. Uncouple vessel propeller shaft. Withdraw shaft so that enough clearance exists to place DryMax® Seal components on shaft in the order they are to be installed.
3. Clean shaft or liner with Isopropyl alcohol.
4. Place DryMax® Seal Assembly in position on shaft. (See pages 2-3 for accurate positioning of DryMax® System Parts).

5. Check positioning of all parts making sure orientation of the DryMax® Seals are positioned with groove for garter spring toward stern tube end (aft) and the lip facing forward.
6. Coupling can now be reinstalled on the shaft. Slide shaft back into position and couple back to the gear box.

## MOUNTING SEAL HOUSING TO STERN TUBE FLANGE OR BULKHEAD

7. Make sure stern tube flange or bulkhead mounting area is clean from any grease or debris. Clean with Isopropyl alcohol. Apply liquid sealant to both sides of seal assembly gasket. (suggested sealant: Permatex #2 or RTV silicone)
8. Mount seal housing to bulk head. Make sure the flanged isolator bushings are installed. Start the bolts by hand to make sure they're not cross threading. The top of the housing needs to be mounted within 22.5 degrees of the 12 o'clock position to allow proper venting of the housing.
9. Using feeler gauges, 5/32 rods, or 5/32 allen wrenches to make sure Seal housing is centered to the shaft. Check clearance around Air Seal Ring. The normal radial clearance is 5/32" (4mm). **Make sure the retainer ring is used for centering, not the Air Seal Ring.**
10. The housing fastening bolts may now be securely tightened using a 8 bolt flange pattern so housing is evenly tightened. For torque values see chart on pg. 11.

Maximum acceptable concentricity from center is 0.020" (.5mm).

Check housing to shaft perpendicularity again.

- a. Mount dial indicator just forward of seal assembly and take another set of readings from shaft to the seal assembly housing face.
- b. Make sure all readings are recorded and send copy to Duramax Marine for warranty record keeping. Keep copy with manual for future reference.

## INSTALLING DRYMAX SEAL COMPONENTS

11. Clean Shaft up to DryMax® assembly using Isopropyl alcohol.
12. Install O-ring for the Mating Ring. Use light grease or o-ring grease on O-ring. (FIG 2)

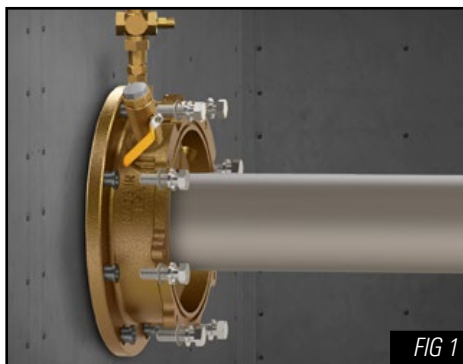

FIG 1

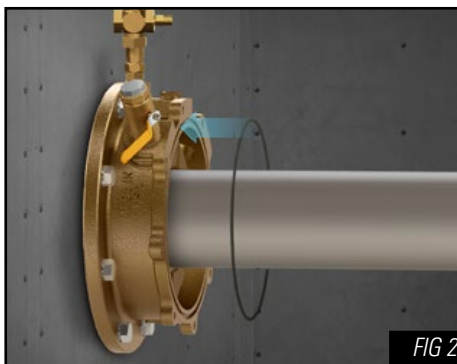

FIG 2

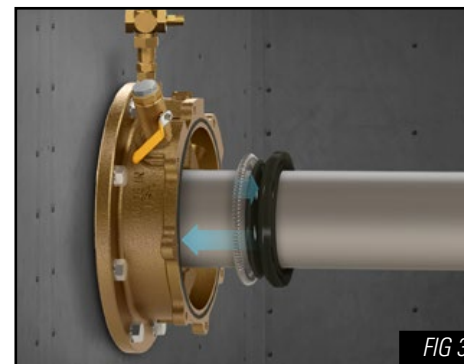

FIG 3

## Retrofit DryMax® Seal Installation

13. If the seal is difficult to slide on the shaft use a liberal coating of liquid dish soap on the shaft to ease assembly.
14. Slide primary Sealing Ring towards the seal housing but do not push in past housing face. Make sure the Seal Ring extends forward of the housing. (FIG 3)
15. Place a light coating of grease in the spring channel on the top side of the Sealing Ring taking care not to get grease on seal face. Attach ends of garter spring together and roll spring into groove on back side of rubber Seal Ring. Wipe Sealing Ring with a soft cloth.
16. Clean the face of the rubber Sealing Ring and Mating Ring using a rag with Isopropyl alcohol or equivalent. Make sure there is no grease on Sealing Ring lip or Mating Ring. Grease on lip can cause damage to Sealing Ring. **NOTE: the Mating Ring is supplied from the factory with both halves securely fastened, sealed and aligned. If halves must be separated during installation make sure to clean Mating Ring edges and reapply sealant (Loctite®510). Securely refasten Mating Ring halves back together. Halves should be perfectly aligned and no edge should be felt at the intersection. If edge can be felt with fingernail use a precision diamond, fine grit file to polish seal face smooth. Remove any sharp edges with fine emery cloth, sand paper, or stone.**
17. Move Sealing Ring towards the housing, but not into housing. Allow Sealing Ring to extend outside the housing. (FIG 3)
18. Push Mating Ring towards the housing, using the Mating Ring to apply even pressure to move the Seal Ring into the housing. (FIG 4)
19. The Mating Ring hardware can be started at this point. Use an eight bolt flange pattern to draw the Mating Ring evenly to the housing.
20. Make sure the Mating Ring's O-ring stays in location then securely tighten all Mating Ring bolts using in an eight bolt flange pattern. (For torque values see chart on pg. 11, Appendix C)
21. Slide Spare DryMax® Seal and position it about 2.5" to 4" (60-100mm) from Seal Assembly. Protect spare garter spring with a light coating of grease and install garter spring. Wrap seal with plastic wrap and then over-wrap with duct tape. Spare Seal should never touch DryMax® Seal Assembly. (FIG 5)
22. Properly ground shaft by installing Earthing Device in location near DryMax® Seal assembly. Make sure ground wire is bonded to vessel's hull. A set screw on side of Earthing Device must be released to permit carbon brush to make contact with the shaft. Position the Earthing Device with 1/4" clearance from the shaft when carbon brush is in the retracted position. (FIG 6)

Follow these instructions to install a DryMax® Seal in a vessel with a pre-existing sealing system. Drymax® can be used in retrofit applications.

1. Take measurements of the existing bolt circle diameter (BCD) on the bulkhead or stern tube flange where the seal will be attached. Record the number of bolt holes and their size.
2. It may be possible for the DryMax® Seal to directly retrofit the existing bolt hole pattern. (FIG 7)  
If this is not possible, Duramax Engineering can design an adapter plate with the same bolt hole configuration as the original seal. The adapter plate will be drilled and tapped for the Drymax® Seal and will be drilled and counter bored for the existing bolt circle. **NOTE: If shaft withdrawal is not planned the adapter plate can be manufactured in a split configuration and mounted around the shaft. The seal housing can also be supplied in a split configuration for larger shaft diameters.**
3. Once an adapter plate has been installed, refer installation instructions on page 4 to complete the installation.

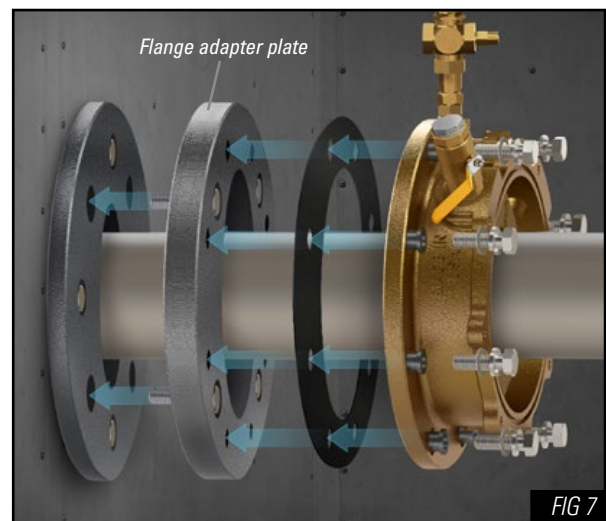

Optional - Stern Tube flange adapter plate

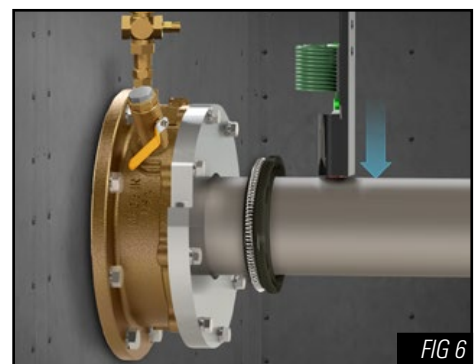
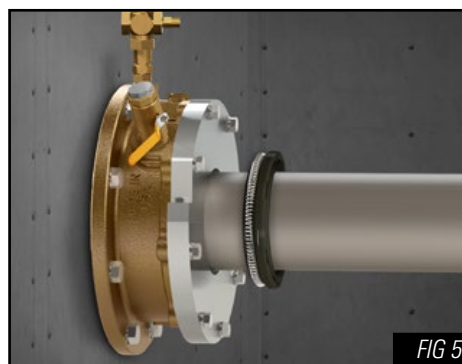
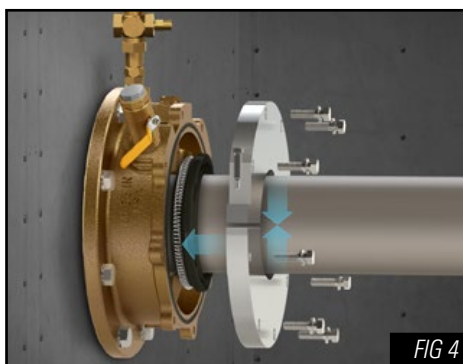

# Piping

## PIPING FOR WATER SUPPLY

### **DryMax® water inlets for water-lubricated bearings**

Force lubricating is not required however, it is recommended. It will ensure a constant supply of water that will extend the life of the Seal Ring. For Johnson Cutless® bearings, water flow should be 2 GPM per inch of shaft diameter at 5 to 7 psi greater than static head pressure. Depending on the shaft diameter, one or two water inlets may be used.

If the water supply inlet is not in use, install the stainless steel plug supplied with seal.

*(Customer supplied ball valve shown)*

## PIPING FOR INFLATABLE SEAL AIR SUPPLY

An air source should be provided to the Air Seal with a pressure release valve. Compressed air is necessary for pressurizing the Air Seal Ring. Air pressure must not exceed 80 PSI. An air regulator should be installed to control the air pressure.

If direct line piping for air supply is not available, a hand pump with pressure gauge can be used with the provided Schrader valve.



LLOYD'S REGISTER  
TYPE APPROVED PRODUCT



# Earthing Device Installation & Testing of System Installation

## INSTALLATION OF SHAFT EARTHING DEVICE

1. Locate a smooth position on the shaft forward of the Seal assembly where the Earthing Device can be mounted and the carbon brush can make easy contact with shaft.
2. Clean the circumference of the shaft in the area in which the carbon brush will make contact. Remove any grease, paint or other debris.
3. Install a support bracket or "L" channel in a convenient location for mounting the shaft Earthing Device. A good location can be projecting from ship floor or to the side of the shaft to support and mount the shaft Earthing Device.
4. Mount shaft Earthing Device to bracket with the end of the device 1/4" away from the shaft. (FIG 8)
5. Release the retaining screw on the side of the device to engage the carbon brush on to the shaft.
6. Connect the wire from the carbon brush to the ships hull and confirm that it is grounded.

**NOTE: Check and clean carbon brush weekly. Make sure to retract the carbon brush should shaft withdrawal become necessary.**

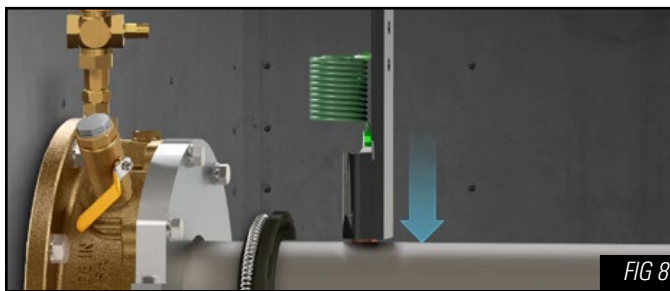

## TESTING OF SYSTEM INSTALLATION

DryMax® Sealing System should be tested after installation for proper operation.

## TESTING WHILE IN DRYDOCK

- a. Connect a garden hose water supply line to the water inlet on the seal housing.
- b. Connect an air supply, pressure regulator and gauge to the DryMax® Air Seal Ring.

- c. Inflate Air Seal Ring to 40 PSI. Close the air valve to the Air Seal. The air pressure in the Air Seal Ring should NOT drop more than 15% in one hour.
- d. Supply water to the housing from the garden hose. Pressure should be regulated so that it is approximately 2 times the draft pressure. Example: if operating draft is 12 feet, then water pressure should be 24 PSI.
- e. Maintain water pressure for 15 minutes and check for any leaks. During this time the primary Seal Ring and the inflated Air Seal are sealing the pressurized water from leaking.

## TESTING WHILE DOCKED

- a. Open vent, once water begins to come out close the vent.
- b. Inflate Air Seal Ring to 40 PSI.
- c. Open vent. There may be a squirt of water at first then there should be no flow coming from the vent.
- d. Hold air pressure for 5 minutes to ensure the Air Seal Ring is holding pressure.
- e. Close vent.
- f. Deflate inflatable Air Seal Ring.
- g. Check seal assembly for leaks at the mounting flange, bolts, and the faceplate.

**SPECIAL NOTE: Never rotate the shaft with the Air Seal Ring inflated. This will damage DryMax® Air Seal Ring.**

## NORMAL OPERATION OF SYSTEM AND SEA TRIALS

1. Line up all flushing line valves in the open position if a flushing system is installed.
2. Purge air from the inflatable Air Seal Ring.
3. Open housing vent plug and purge any air trapped in housing.
4. Close housing vent plug.
5. Rotate propeller shafts and look for abnormalities.
6. During sea trials, check the temperature of the wear plate by placing your hand on the exterior of the Mating Ring. Depending on the seawater temperature the temperature of the Mating Ring should not exceed 125° F (50° C).

**NOTE: It may take up to 20 hours of operation for the Seal Ring to properly bed-in to the DuraChrome® Mating Ring. Temperatures of the Mating Ring might be higher during this period.**

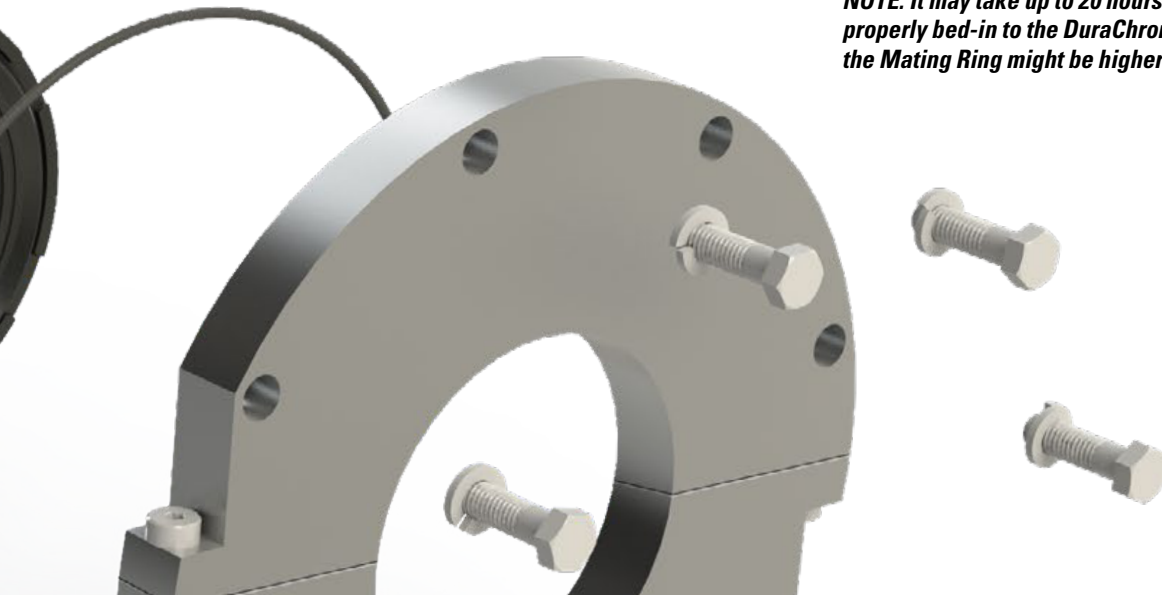

## DryMax® Seal Ring Replacement with Vessel in Water

When the primary Seal Ring requires replacement, it can be done with the vessel in the water. The inflatable air seal permits replacement of primary Seal Ring. The Mating Ring is a split design and is reversible and can be quickly put back into service. A secondary Seal Ring is supplied with each DryMax® Seal Assembly. It can be moved into position when active Seal Ring needs replacement.

**NOTE: When the Mating Ring face experiences wear in excess of 0.020" (0.5mm), it should be re-machined and used again. Machining should be even on each side of Mating Ring so alternate the wear plate usage. Refer to page 11; Appendix E for machining recommendations and tolerances.**

1. Unwrap and clean secondary DryMax® Seal Ring. Clean the face of the rubber Sealing Ring using a rag with Isopropyl alcohol. Make sure there is no grease on Sealing Ring lip or Mating Ring face. Grease on lip can cause damage to Sealing Ring and prevent proper sealing.
2. Make sure that the shaft is stopped is not capable of rotating. Shaft rotation while the Air Seal Ring is inflated can damage it.
3. Pressurize the Air Seal Ring to 40 PSI as needed to seal out sea water.
4. Open Vent at top of the DryMax® Seal housing and make sure no water is coming out of vent. If the water flow continues out of the vent a diver must be sent down to plug the stern tube.  
**NOTE: Do NOT remove Mating Ring unless this step has been satisfactorily completed.**
5. With water flow from the vent stopped, remove the flange bolts from the Mating Ring and slide forward. Now remove the 2 shoulder bolts and split the Mating Ring halves. Remove Mating Ring from shaft and set aside. (FIG 9)
6. Slide the worn Seal Ring out of the DryMax® housing. Remove the garter spring from the seal and cut rubber seal off shaft.

7. Clean sealing edges of Mating Ring with Isopropyl alcohol and a wire brush if necessary. Remove old sealant. Reapply sealant (*Loctite® 510 supplied*) and bolt Mating Ring halves back together. Place Mating Ring on the shaft forward of the spare Seal Ring making sure to reverse the Mating Ring to the unworn side. Check Mating Ring for sharp edges where the halves meet. Remove any sharp edges with fine emery cloth, sand paper or stone.
8. Clean Shaft up to DryMax® assembly using Isopropyl alcohol. Inspect and clean seal housing components as necessary.
9. Reinstall housing O-ring. Use light grease or o-ring grease on O-ring. (FIG 10)
10. Slide DryMax® Replacement Sealing Ring towards the seal housing but do not push in past housing face. Make sure the Seal Ring extends outside of the housing. (FIG 11)
11. Push Mating Ring towards the housing, using the Mating Ring to apply even pressure to move the Seal Ring into the housing. (FIG 12)
12. Install the Mating Ring hardware using an eight bolt flange pattern to draw the Mating Ring evenly to the housing.
13. Make sure the Mating Ring's O-ring stays in location and securely tighten all Mating Ring bolts using in a eight bolt flange pattern. (For torque values see chart on pg. 11, Appendix C)
14. Release the air pressure from the Air Seal Ring. Make sure there is water flowing from the vent and close the air vent. Check DryMax® Seal Assembly for leaks.
15. Re-check the Air Seal Ring to CONFIRM it is fully deflated. Once these steps are followed and completed, the shaft can be rotated and the vessel can get underway. (FIG 13)

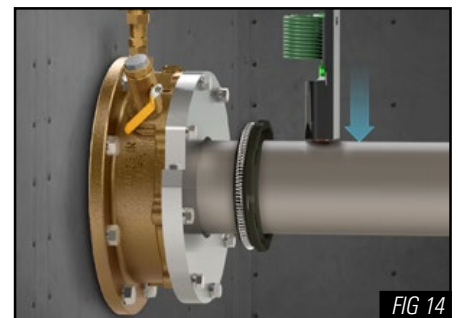
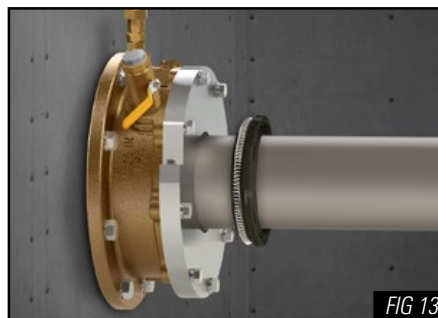
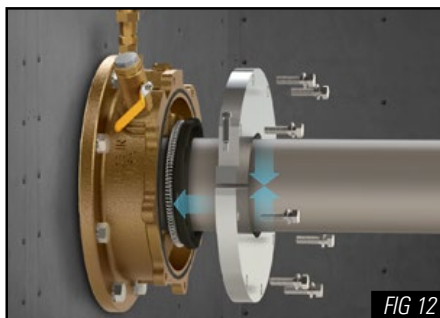
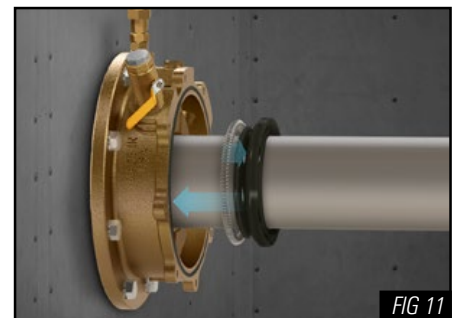
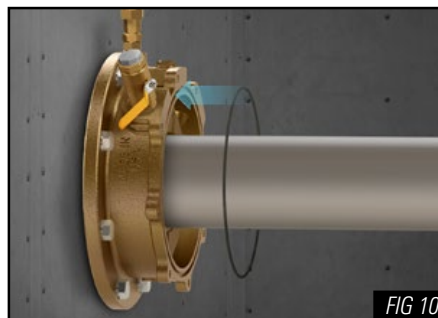
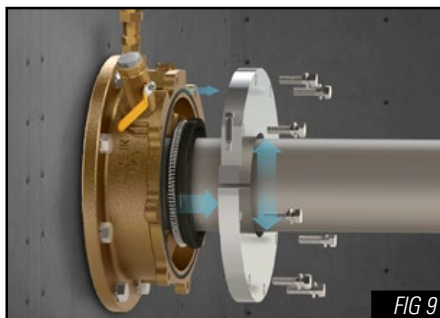

# DryMax® System Inspection & Replacement Check List

MAINTENANCE / INSPECTION CHECKLIST		
PART	TIMING	DESCRIPTION
<b>SEAL ASSEMBLY CONDITION</b>	<b>Once daily</b>	Check visually for any water leakage. Make note if there is an increase or decrease in leakage rate. Some leakage from Seal Ring is acceptable as it contributes to the lubrication and cooling of the seal.
<b>SHAFT EARTHING DEVICE</b>	<b>Once weekly</b>	Check condition of the carbon brush. Check for any dirt or debris on the shaft surface and clean area thoroughly.
<b>AIR SEAL RING</b>	<b>Monthly, to exercise seal</b>	Test 30 days prior to docking. Pressurize to 40 PSI. Open air vent. No water should be coming out. If there is, increase air pressure up to a maximum of 80 PSI to achieve seal. If this does not stop water leaking from vent the Air Seal Ring has been damaged and must not be used.
<b>MAJOR INSPECTION</b>	<b>Annually</b>	<p>Complete inspection of primary Sealing Ring. Look for any unusual wear. Clean any debris from seal face using Isopropyl alcohol.</p> <p><i>Note: Check for excessive wear or deformation of DryMax® Active Sealing Ring. Check garter spring. Inspect behind the Seal Ring for debris which could prevent water flow.</i></p> <p>Check condition of DuraChrome Mating Ring.</p> <p><i>Note: If wear on Mating Ring is over 0.020" it should be reversed. If both sides of Mating Ring have been worn they should be machined in a lathe. Refer to resurfacing procedure on page 11; Appendix E.</i></p> <p>Check condition of surface of shaft. Look for any debris, cracks, corrosion or pitting. Shaft surface finish should be: ≤ 64 micro inches RMS.</p> <p><i>Note: Repair any damage on shaft.</i></p>

PARTS REPLACEMENT		
PART	REPLACE	DESCRIPTION
<b>DRYMAX® SEAL RING</b>	<b>2 to 4 years</b>	The rubber Seal Ring life is approximately 2 to 4 years depending on operating environment. Always replace the garter spring when rubber Seal Ring is replaced.
<b>AIR SEAL RING</b>	<b>Approximately 5 years</b>	Life of the Air Seal Ring is approximately 5 years. Should the vessel need to drydock prematurely the opportunity should be taken to replace the Air Seal Ring at that time. Replace Air Seal Ring immediately if it has been damaged and does not seal. Refer to test procedure on page 7.
<b>DURACHROME® REVERSIBLE MATING RING</b>	<b>After resurfacing a maximum amount.</b>	<p>The DuraChrome Mating Ring can be reversed one time before it will be necessary to re-machine the surface in a lathe.</p> <p><b>RESURFACING DURACHROME® MATING RING</b></p> <p>If the amount of wear on the sliding surface is over 0.020" (0.5mm) it should be machined on a lathe. If the wear has not exceeded these limits the surface can be polished with a fine emery cloth before re-installing.</p> <p>When machining use the speeds and feeds provided in the appendix for optimal surface finish. The required surface finish of the Mating Ring is: 16-32 micro inches RMS</p>
<b>O-RING</b>	<b>Approximately 5 years</b>	The life of the O-ring is about 5 years. Check for any tears or weak points in the O-ring at the bonded joint (if applicable). The O-ring should be replaced when removing the Mating Ring if possible.

APPENDIX A: DRYMAX SEAL CALIBRATION AND ISSUE ANALYSIS

CONDITION	NORMAL OPERATION	IRREGULAR OPERATION
<b>DuraChrome® Mating Ring is running hot. An inspection of the DuraChrome Mating Ring may be done by feeling it with your hand or with any temperature sensing unit.</b>	During normal operation the Mating Ring should be warm to the touch < 125° F (50° C). Initial operating temperature of new seal may be higher for approximately 20-30 hours of operation until seal has properly broken in.	Mating Ring is too hot to touch (>125° F) after initial break in period. There is a smell of burning rubber.
<b>Water leakage limits exceeded</b>	During shaft rotation some small amount of leakage can occur. With a new seal leakage should be less than 0.5 gallons per day. The Seal Ring should be replaced when leakage exceeds: 3"-7" Shaft > 1 gallon daily 7.25"-12" > 3 gallons daily 12.25-36" > 6 gallons daily	Water leakage exceeds recommended daily limit
<b>Air Seal Ring not sealing</b>	When pressurized to 40 PSI the air vent may be opened and no water should continue to come out. When confirmed the Mating Ring can be removed for seal inspection.	Air Seal Ring is damaged or worn out and needs to be replaced.  Air Seal Ring can be pressurized but water still leaking from air vent

APPENDIX B: SEAL SPACE REQUIREMENTS

Model	Shaft Size (in)	Shaft Size (mm)	Flange OD (in)	Flange OD (mm)	Length (in)	Length (mm)	BCD (in)	BCD (mm)
400	3.5 - 4.49	89 - 114	11 1/8	283	4 1/2	115	9 7/8	250.8
500	4.5 - 5.49	115 - 139	12 1/8	308	4 1/2	115	10 7/8	276.2
600	5.5 - 6.49	140 - 165	13 1/8	334	4 1/2	115	11 7/8	301.6
700	6.5 - 7.49	166 - 190	14 1/8	359	4 1/2	115	12 7/8	327.0
800	7.5 - 8.49	191 - 215	15 1/8	385	4 1/2	115	13 7/8	352.4
900	8.5 - 9.49	216 - 241	16 3/8	416	5	127	15	381.0
1000	9.5 - 10.49	242 - 266	17 3/8	442	5	127	16	406.4
1100	10.5 - 11.49	267 - 292	18 3/8	467	5	127	17	431.8
1200	11.5 - 12.49	293 - 317	19 3/8	493	5	127	18	457.2
1300	12.5 - 13.49	318 - 342	20 3/8	518	5	127	19	482.6
1400	13.5 - 14.49	343 - 368	21 3/8	543	5	127	20	508.0
1500	14.5 - 15.49	369 - 393	22 5/8	575	5 1/8	131	21 1/8	536.6
1600	15.5 - 16.49	394 - 419	23 5/8	601	5 1/8	131	22 1/8	562.0
1700	16.5 - 17.49	420 - 444	24 5/8	626	5 1/8	131	23 1/8	587.4
1800	17.5 - 18.49	445 - 469	25 5/8	651	5 1/8	131	24 1/8	612.8
1900	18.5 - 19.49	470 - 495	26 5/8	677	5 1/8	131	25 1/8	638.2
2000	19.5 - 20.49	496 - 520	27 5/8	702	5 1/8	131	26 1/8	663.6
2100	20.5 - 21.49	521 - 546	28 7/8	734	5 1/8	131	27 1/4	692.2
2200	21.5 - 22.49	547 - 571	29 7/8	759	5 1/8	131	28 1/4	717.6
2300	22.5 - 23.49	572 - 596	30 7/8	785	5 1/8	131	29 1/4	743.0
2400	23.5 - 24.49	597 - 622	31 7/8	810	5 1/8	131	30 1/4	768.4
2500	24.5 - 25.49	623 - 647	32 7/8	836	5 1/8	131	31 1/4	793.8
2600	25.5 - 26.49	648 - 673	33 7/8	861	5 1/8	131	32 1/4	819.2
2700	26.5 - 27.49	674 - 698	35 1/8	893	5 1/8	131	33 3/8	847.7
2800	27.5 - 28.49	699 - 723	36 1/8	918	5 1/8	131	34 3/8	873.1
2900	28.5 - 29.49	724 - 749	37 1/8	943	5 1/8	131	35 3/8	898.5
3000	29.5 - 30.49	750 - 774	38 1/8	969	5 1/8	131	36 3/8	923.9
3100	30.5 - 31.49	775 - 800	39 1/8	994	5 1/8	131	37 3/8	949.3
3200	31.5 - 32.49	801 - 825	40 1/8	1020	5 1/8	131	38 3/8	974.7
3300	32.5 - 33.49	826 - 850	41 5/8	1058	5 1/8	131	39 5/8	1006.5
3400	33.5 - 34.49	851 - 876	42 5/8	1083	5 1/8	131	40 5/8	1031.9
3500	34.5 - 35.49	877 - 901	43 5/8	1109	5 1/8	131	41 5/8	1057.3
3600	35.5 - 36.49	902 - 927	44 5/8	1134	5 1/8	131	42 5/8	1082.7

POSSIBLE CAUSE	POTENTIAL REMEDY
Water pressure going into seal is too high	Reduce water pressure to minimum required for stern tube bearings.
Debris has clogged stern tube	Remove debris.
Debris has clogged Sealing Ring	Follow procedure on page 9 for inspection and maintenance of Seal Ring.
Improperly installed Seal Ring	Remove Mating Ring and re-install according to instructions on pages 4-5.
Inflatable ring is pressurized	Open valve to depressurize inflatable seal.
Air trapped in housing	Open air vent until all air is purged and water is coming through.
Debris has clogged Sealing Ring	Clean Seal Ring and remove dirt or debris from Seal Ring chamber.
Wear on Sealing Ring has exceeded limits	Follow procedure on page 9 for inspection and replacement of Seal Ring.
Wear on DuraChrome Mating Ring has exceeded 0.020" (0.05mm)	Follow procedure on page 8 for reversing and replacing Seal Ring.
Leakage between shaft and Seal Ring	There may be pitting or damage to the shaft surface. Follow inspection procedure on page 9 and make necessary repairs.
Inflatable ring was damaged by rotating the shaft with seal was pressurized.	Replacement of inflatable air seal must be completed as soon as possible. Dry-docking vessel is usually required. Emergency seal replacement while vessel is in water can be performed by factory trained personnel.
Insufficient air pressure	Increase air pressure until water stops.
Pitting or damage to shaft in area of Air Seal Ring	Dry-dock vessel or have diver plug stern tube & inspect seal. Make repairs to shaft.

APPENDIX C: BOLT TORQUE VALUES	
Bolt Size	Torque Values
1/4	18 in.-lb.
3/8	20 ft.-lb.
1/2	45 ft.-lb.
5/8	96 ft.-lb.
3/4	131 ft.-lb.
7/8	202 ft.-lb.
1	299 ft.-lb.
1 1/8	320 ft.-lb.
1 1/4	345 ft.-lb.

APPENDIX D: INSTALLATION CHECK SHEET		
#	DESCRIPTION:	DATE COMPLETED
1	Check squareness of DryMax® mounting flange with dial indicator	
2	Mount Adapter Ring - if required	
3	Mount DryMax® Seal Ring, check concentricity and squareness	
4	Fill out measurement records	
5	Install DryMax® O-ring for Mating Ring	
6	Install DryMax® Seal garter spring	
7	Install DryMax® Seal Ring, push in place with DuraChrome® Mating Ring	
8	Push active Seal Ring with Mating Ring bolts, tighten in star pattern	
9	Install spare Sealing Ring and garter spring	
10	Protect spare Sealing Ring	
11	Make any necessary water connections	
12	Make air fitting connections	
13	Test seal assembly per testing instructions	
DRYMAX SERIAL NUMBER: _____ / _____ INSTALLATION DATE: ____/____/____ IN SERVICE DATE: ____/____/____		

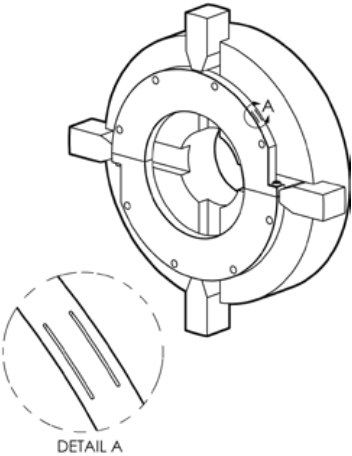
APPENDIX E: RE-MACHINING THE DURACHROME MATING RING – SPEEDS AND FEED		
DESCRIPTION	MACHINING DIAGRAM	SPECIFICATIONS/INSTRUCTIONS
<p>When machining the DuraChrome® Mating Ring it is recommended that a carbide cutting tool is used. Care should be taken to machine both sides of the Mating Ring evenly to prolong life.</p> <p><b>Note: Each side of Mating Ring can be machined down to the indicator marks. (See DETAIL A.)</b></p>		<p><b>CUTTING TOOL:</b> CNMG 432  <b>SPINDLE SPEED:</b> 150 SFM  <b>FEED RATE:</b> .006 IN/REV</p> <p><b>MATING RING SURFACE FINISH TOLERANCE:</b> 16-32 micro inches RMS  <b>MATING RING TOTAL THICKNESS:</b> 1" (25.4mm)</p> <p><b>Machining the Mating Ring on the DryMax Housings.</b></p> <ol style="list-style-type: none"> <li>1. Properly hold the Mating Ring in the chuck. Use a 4 or 6 jaw chuck. (See DETAIL A.)</li> <li>2. The jaws of the chuck are on the outside of the Mating Ring, and located on the split line.</li> <li>3. Take your cuts from the inside diameter of the Mating Ring to the outside of the Mating Ring.</li> <li>4. Remove 0.002-0.005 inch per cut as you face the surface.</li> <li>5. Coolant must be used to keep the temperatures down.</li> <li>6. Use a 0.006 inch Feed rate.</li> <li>7. Cut at 150 SFM (Surface Feet per Minute)</li> </ol> <p><b>150 SFM = .262 x Diameter x RPM</b>  <b>For a Mating Ring of 16 inch: 150 SFM = .262 x 16 x RPM</b>  <b>RPM= 36</b></p>

INNOVATION.  
EXPERIENCE.  
RESULTS.

Duramax Marine® is committed to providing excellence in every product we manufacture. Our Johnson Cutless® marine and industrial bearings, heat exchangers, impact protection systems and sealing systems are known worldwide for their engineered quality and dependable performance. Please contact the factory for information on any of the following Duramax Marine® products:



## JOHNSON CUTLESS® WATER-LUBRICATED BEARING SYSTEMS

Johnson Cutless® Sleeve and Flanged Bearings

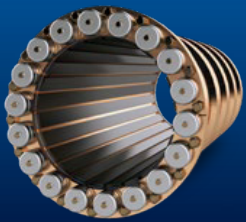

## DURAMAX® ADVANCED WATER-LUBRICATED BEARING SYSTEMS

Johnson® Demountable Stave Bearings  
ROMOR® I Stave Bearings and Segmental Housings  
ROMOR® C- Partial Arc Bearings  
DMX® Polymer Alloy Bearings  
DuraBlue® Bearings, Rudder & Pintle Bushings, Thrust Washers, and Wear Pads  
Industrial Pump Bearing Systems



## DURAMAX® HEAT EXCHANGE SYSTEMS

DuraCooler® Keel Coolers  
Duramax® Demountable Keel Coolers  
Duramax® BoxCoolers

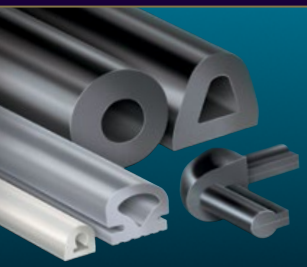

## DURAMAX® IMPACT PROTECTION SYSTEMS

Johnson® Commercial Dock Bumpers, Fenders & Tow Knees  
LINERITE® Composite Batterboard Systems



## DURAMAX® SHAFT SEALING SYSTEMS

DryMax® Shaft Seal  
Duramax® Mechanical Shaft Seal  
Johnson® Heavy-Duty Air Seal Stuffing Boxes  
Duramax® Ultra-X® High Performance Compression Packing

©2024 Duramax Marine®  
17990 Great Lakes Parkway  
Hiram, Ohio 44234 U.S.A.  
PHONE 440.834.5400  
FAX 440.834.4950  
info@DuramaxMarine.com  
www.DuramaxMarine.com

Duramax Marine® is an ISO 9001:2015 Certified Company

# DURAMAX MARINE®